

Electronic Jet Kit™ Instructions



Thank you for choosing the Techlusion Electronic Jet Kit, the TFI. This unit is designed for use with all V-Rod's.

This product is a perfect fit for stock bikes with all exhaust and intake mods. It is also capable of handling the fuel needs of cubic inch kits, light cams, and a variety of head porting.

This is an Electronic Jet Kit. Like jet kits in the past, the more you modify, the more responsibility you take in getting your fuel curve right. Going to Dobeckperformance.com will help you obtain better high horsepower tuning.

TOOLS REQUIRED

- **This is about a 60-minute install time.**
- **The tools required to disconnect the negative terminal of the battery.**
- **The tools required to remove your seat.**
- **The tools required to remove your air box cover.**
- **Last but not least a small screwdriver.**

V-Rod Install

First: Remove the tank shell, left front frame cover and the horn assembly.

1. **Locate and disconnect the IAT sensor. (see figure 1)**
2. **Use a screwdriver to disengage the 8 clips retaining the airbox lid. The front clip is not visible and must be reached from the right side. (see figure 2)**
3. **Remove the plastic nut, air filter cover and filter. (see figure 3)**
4. **Loosen and remove the rear cylinder crankcase breather hose at the head cover. (see figure 4)**
5. **Pull the breather hose from the fitting inside the airbox. Slide the large O rings up the stacks to access the stack mounting screws. (The O rings retain the screws should they become loose.) Remove the 6 screws and the velocity stacks. (see figure 5)**
6. **Disengage the front crankcase breather hose and remove the airbox floor. There is no clamp on this hose. (see figure 6)**
7. **View from left, stock. (see figure 7)**
8. **View from right. Depress the locking bails and remove the injector connectors. Rear first, then front. Do not pull the wires. (see figure 8,9)**
9. **Feed the injector harness out the left side. (see figure 10)**
10. **Route the TFI harness as shown. The TFI wiring should be between the frame and the OEM harness that goes over the battery negative. (see figure 11)**
11. **Continue pulling the TFI harness through, routing it on top of the main (plastic braid covered) harness. Route the connectors inside the frame, down through the engine V and out where the stock injector harness is. (see figure 12)**
12. **Connect the TFI harness to the stock harness. Pay attention to the color-coding. The TFI harness with the yellow and white leads is for the front injector. It is essential the connectors be installed properly at the front and rear injectors. (see figure 13)**
13. **Feed the TFI injector connectors under the throttle body and connect them to their respective injectors. Install the horn. (see figure 14)**
14. **Pull any excess slack in the TFI harness back to the front. (see figure 15)**
15. **Connect the TFI ground wire to the battery negative cable as shown (see figure 16)
Cable tie the TFI harness and ground lead to the main wiring harness. Reinstall the airbox floor, crankcase breathers, velocity stacks, O rings, air filter assembly and airbox lid. Make sure you reconnect the IAT sensor.**
16. **Use the Velcro provided to mount the TFI to the top of the battery.**

Tuning

With the bike fully warmed up, locate the green light and the pot right below it. At idle you should see all the all the lights flashing, up to 1500rpm, then you should have a solid green light. Raise the RPM up to a high idle or about 1800-RPM if you have a Tach. Once there, slowly turn the green pot clockwise from the 1:00 position (or off) until you achieve the highest RPM or smoothest running sound (just like you would if you had a mixture screw on a carburetor). You should find that the best setting is between 2:30 and 4:00. If you slowly turn on the green pot and the engine does not accept any more fuel (RPMs drop when adding fuel) then you have one or more of these problems. (see troubleshooting **Motorcycle**)

Next locate the yellow light and the pot below it. This pot adjustment acts as an accelerator pump adjustment. Anytime you see the light on, it means that this pot is adding fuel. You will notice that you can take the RPM slowly up to 3000 in neutral and see no yellow light. By whacking the throttle wide open quickly you should see the yellow light come on. Try to add as much as you can until the bike says it is too much then back off two clock positions. This yellow pot adds most of its fuel below 4000 RPM and full throttle acceleration.

The red light pot is your main jet. It adds about 5 points of a main jet for every clock position. For example, one clock position is the same as 170 to 175 main jet. All we can say about setting up this pot is to use the base setting that comes closest to your bike's modifications. Then use the same method you used, in setting up your carbureted bikes.

Troubleshooting

TFI

If the green LED is flashing by itself there is an incomplete connection with the injector connectors with the yellow & white leads from the TFI. If the red LED is, there is an incomplete connection with the injector connectors with green & gray leads from the TFI. Please confirm that the connectors and wires are firmly in place.

Motorcycle

(Order from most common to least common)

1. Engine not fully warmed up.
2. A vacuum leak on the intake.
3. High lift cams affecting map at light loads and low RPMS.
4. The loss of TPS and ECU sync.
5. Cylinder head temp sensor malfunction.

Problem poor mileage

Solution:

- 1. Check your green pot settings. In the hundreds of installs performed, we have never gone beyond the 4:00 settings. Try backing down the settings slightly.**
- 2. The RPM pot is adjusted too low. Make sure it's at least at the 7:00 setting, this means the main comes in at around 6800 rpm.
Make sure your engine passes the 1800 rpm test at the beginning of the troubleshooting chapter.**

If you still have mileage issues call tech support at 877-764-3337.

FULL THROTTLE

Simply add or subtract fuel with the red light pot to determine if the problem is better or worse. This lets the engine dictate additional adjustments or call tech support at 877-764-3337.

Some vehicles modifications with Techlusion Inc. products must not be used on public roads and in some cases may be restricted to close course competition. Those products not identified as US EPA legal are intended for off-road or marine applications only. Not intended for use on emission controlled vehicles.

Electronic Jet Kit™ Instructions

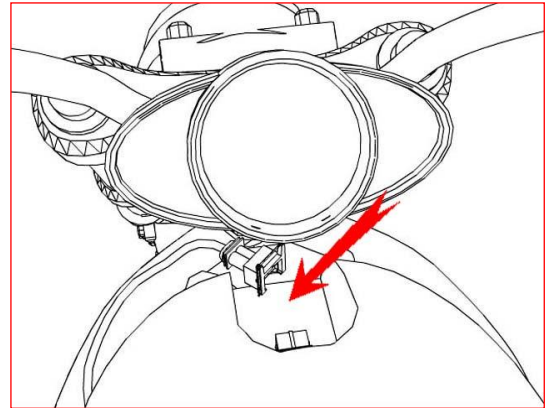
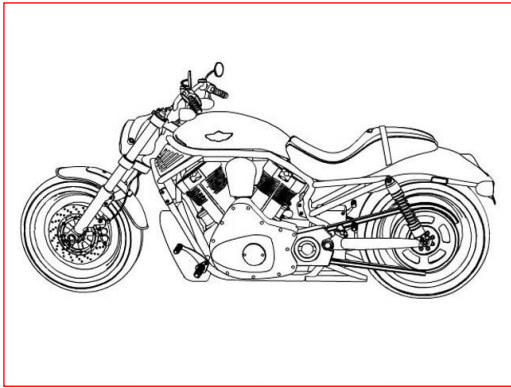

Figure 1

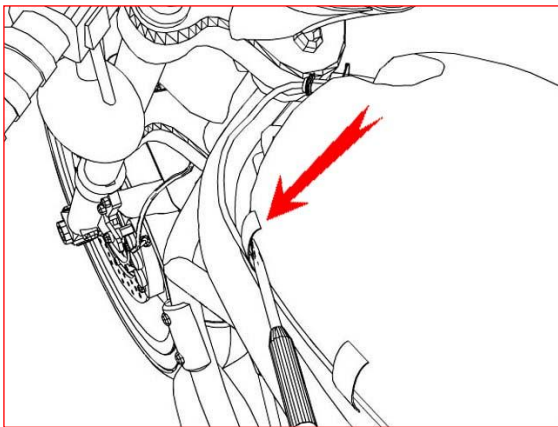

Figure 2

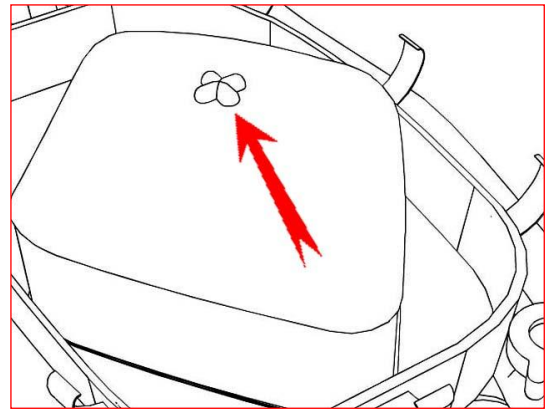

Figure 3

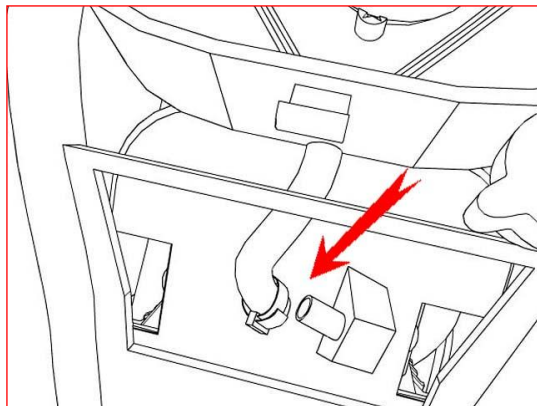

Figure 4

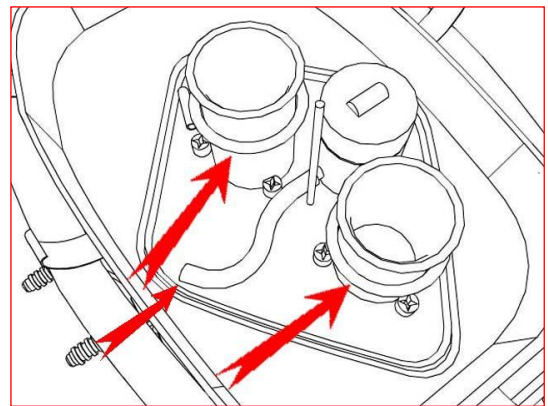

Figure 5

Electronic Jet Kit™ Instructions

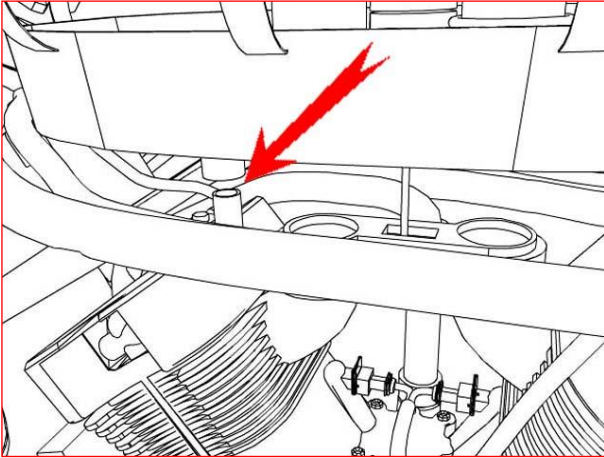

Figure 6

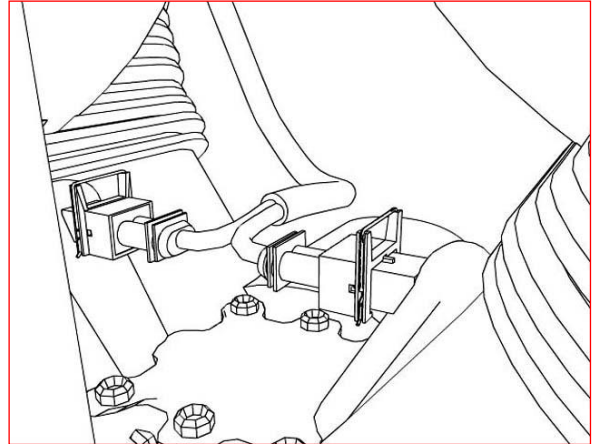

Figure 7

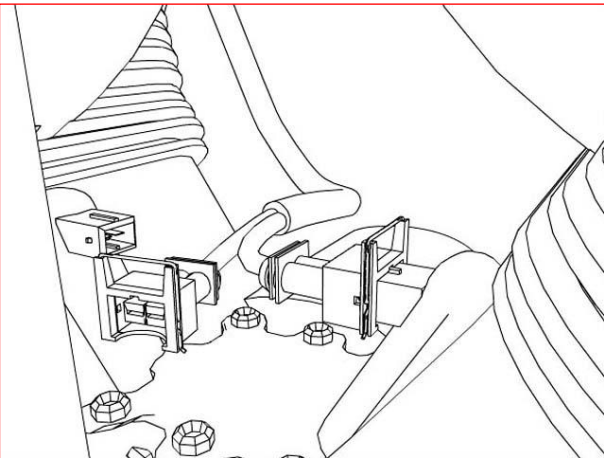

Figure 8

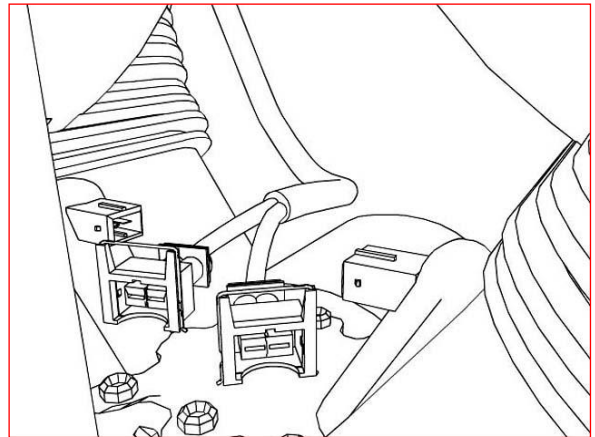

Figure 9

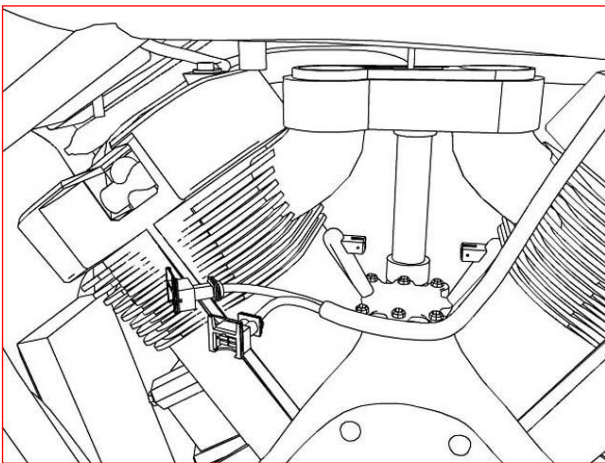

Figure 10

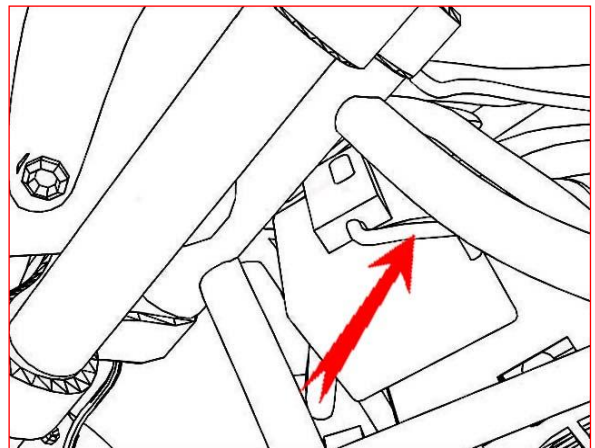

Figure 11

Electronic Jet Kit™ Instructions

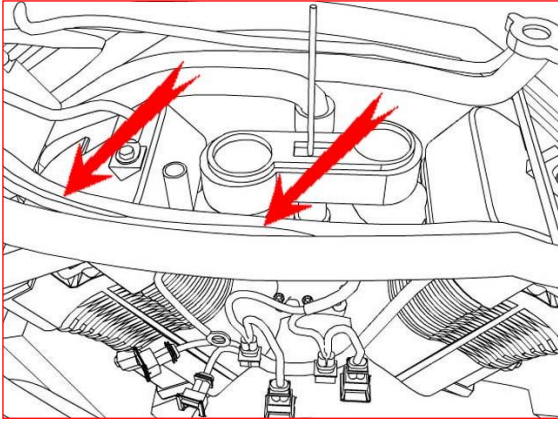

Figure 12

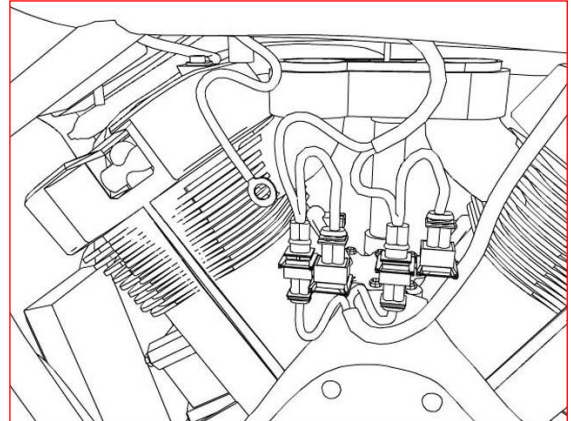

Figure 13

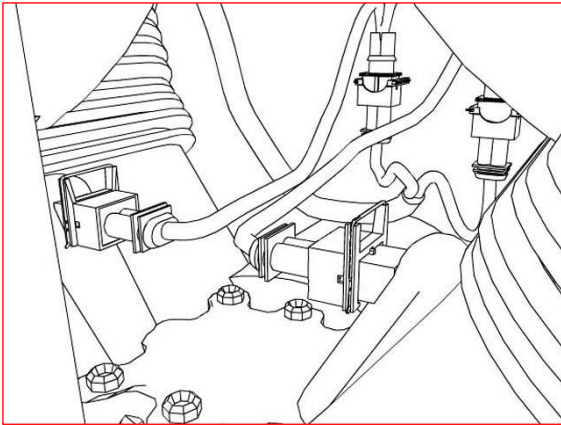

Figure 14

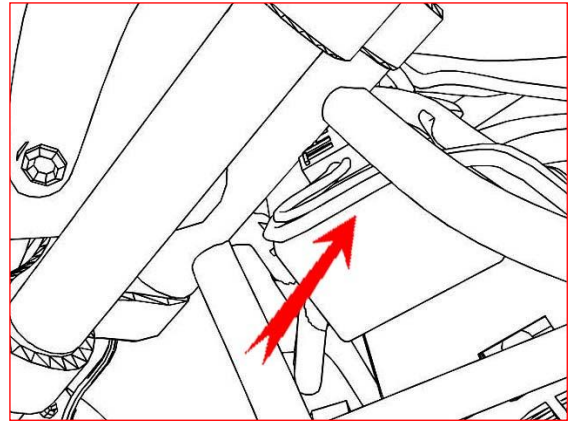

Figure 15

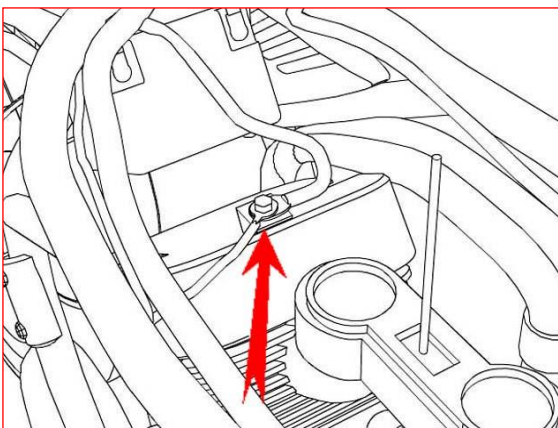
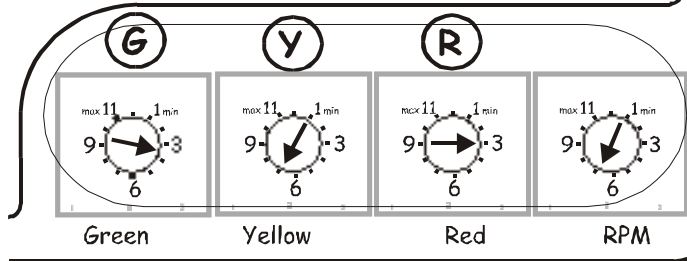
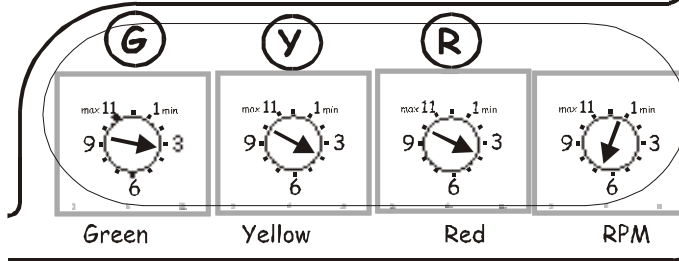

Figure 16

Harley V-Rod - Stock/ No download



Harley V-Rod - #1 Download w/Aftermarket Exhaust



2-year Unlimited Mileage Warranty

Techulsion warrants that this product carries a warranty for 2-years from date of purchase against original defects in materials and workmanship. Should this product fail to perform for either of the above reasons, Techulsion will repair or replace it with an equivalent product at no charge, except for postage, to the original retail purchaser.

*****IMPORTANT*****

To obtain the benefits of this warranty, the retail purchaser must first call 1-877-764-3337 to obtain a Return Authorization Number, then send the product with proof of purchase and postage prepaid to:

**Dobeck Performance
157 Progressive Dr.
Belgrade, MT 59714**