

Electronic Jet Kit™ Instructions



Thank you for choosing the Techlusion Electronic Jet Kit, the TFI. The TFI is usable only for 2006 Touring and Softail model fuel injected Harley Davidson's.

This product is a perfect fit for stock bikes with all exhaust and intake mods. It is also capable of handling the fuel needs of cubic inch kits, light cams, and a variety of head porting.

This is an Electronic Jet Kit. Like jet kits in the past, the more you modify, the more responsibility you take in getting your fuel curve right. Going to Dobeckperformance.com will help you obtain better high horsepower tuning.

TOOLS REQUIRED

- This is about a 60-minute install time.
- The tools required to disconnect the negative terminal of the battery.
- The tools required to remove your seat and side cover (if necessary).
- The tools required to loosen & prop up the fuel tank.
- Last but not least a small screwdriver.

1. Before installing the TFI you must first disconnect the negative lead from the battery.
2. Determine a location for the TFI unit. Suggested locations are as follows: Under the seat or behind the side cover.
3. Making sure that your motorcycle is cold, loosen and lift up the fuel tank (be sure to disconnect the fuel line using the quick disconnect feature on the fuel fitting, **DO NOT UNSCREW THE FITTING**) and remove the front and rear mounting bolts you will need something to hold the fuel tank up (block of wood or a towel) from the frame to gain access to the injectors.
4. Underneath the fuel tank you will locate the fuel injectors. (For Touring see figure #5, for Softail figure #4).
5. Disconnect the factory injector connectors from the fuel injectors and replace with the TFI injector connectors from the TFI unit, **it does not matter which order they are hooked up.** (For Touring see figure #6,7,8, Softail figure #5,6,7). **It is a good idea to make sure there is a little slack in the harness to prevent engine vibration from damaging/breaking a wire on the connectors.**
6. Replace the fuel tank. (Making sure that all mounting bolts are in place and fuel connections are correct).
7. Connect the TFI ground lead to the negative terminal of the battery along with the factory ground lead. (For Touring see figure #4, Softail figure #3).
8. With the rubber plug removed from the TFI, turn the motorcycle key switch to the “ON” position. As the bikes electrical system goes through initial start up mode you will see LED’s flashing on the TFI for a few seconds then go out, this is normal.
9. Start the motorcycle. The green LED should now be on steady and the yellow will flash rapidly for about 15 seconds, and then go out. If the green or red LEDs continue flashing after startup please refer to the “**TFI**” section in the troubleshooting guide.

Tuning

So, with our box on and the bike fully warmed up, with a screwdriver in hand, locate the green light and the pot right below it. Raise the RPM up to a high idle or about 1800-RPM if you have a Tach. Once there, slowly turn the green pot clockwise from the 1:00 position (or off) until you achieve the highest RPM and smoothest running sound (just like you would if you had a mixture screw on a carburetor). You should find that the best setting is between 2:30 and 4:00. If you slowly turn on the green pot and the engine does not accept any more fuel (RPMs drop when adding fuel) then you have one or more of these problems. (See troubleshooting **Motorcycle**)

Next locate the yellow light and the pot below it. This pot adjustment acts as an accelerator pump adjustment. Anytime you see the light on, it means that this pot is adding fuel. You will notice that you can take the RPM slowly up to 3000 in neutral and see no yellow light. By whacking the throttle wide open quickly you should see the yellow light come on. Try to add as much as you can until the bike says it is too much then back off two clock positions. This yellow pot adds most of its fuel below 4000 RPM and full throttle acceleration.

The red light pot is your main jet. It adds about 5 points of a main jet for every clock position. For example, one clock position is the same as 170 to 175 main jet. All we can say about setting up this pot is to use the base setting that comes closest to your bike's modifications. Then use the same method you used, in setting up your carbureted bikes. Good Luck.

Troubleshooting

TFI

If the green LED is flashing by itself there is an incomplete connection with the injector connectors to the yellow & white leads from the TFI. If the red LED is, there is an incomplete connection to the injector connectors with green & gray leads from the TFI. Please confirm that the connectors and wires are firmly in place.

Motorcycle

(Order from most common to least common)

1. Engine not fully warmed up.
2. A vacuum leak on the intake.
3. High lift cams affecting map at light loads and low RPMS.
4. The loss of TPS and ECU sync.
5. Cylinder head temp sensor malfunction.

Problem poor mileage

Solution:

1. Check your green pot settings. In the hundreds of installs performed, we have never gone beyond the 4:00 settings. Try backing down the settings slightly.
2. The RPM pot is adjusted too low. Make sure it's at least at the 4:00 setting, this means the main comes in at around 4000 rpm.
Make sure your engine passes the 1800-RPM test at the beginning of the "Tuning" chapter.

If you still have mileage issues call tech support at 877-764-3337.

FULL THROTTLE

Simply add or subtract fuel with the red light pot to determine if the problem is better or worse. This lets the engine dictate additional adjustments or call tech support at 877-764-3337.

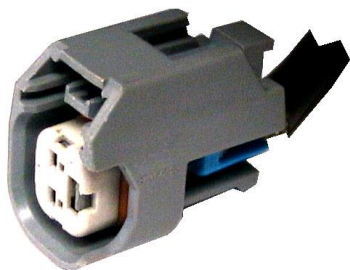

Please note that the '06 Harley Davidson Injectors have changed. Your connector will look like the image above. All other information will remain the same.

Some vehicles modifications with Techlusion Inc. products must not be used on public roads and in some cases may be restricted to close course competition. Those products not identified as US EPA legal are intended for off-road or marine applications only. Not intended for use ON emission controlled vehicles.

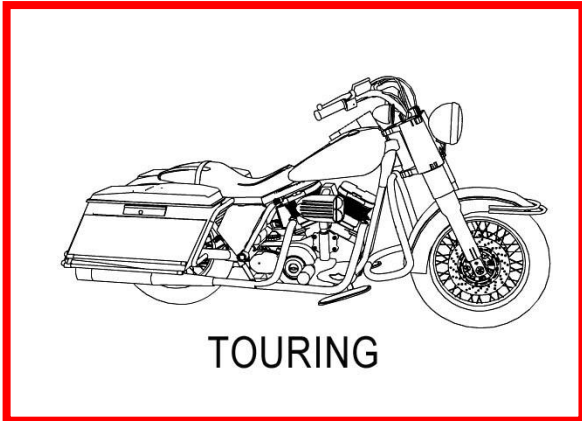

TOURING

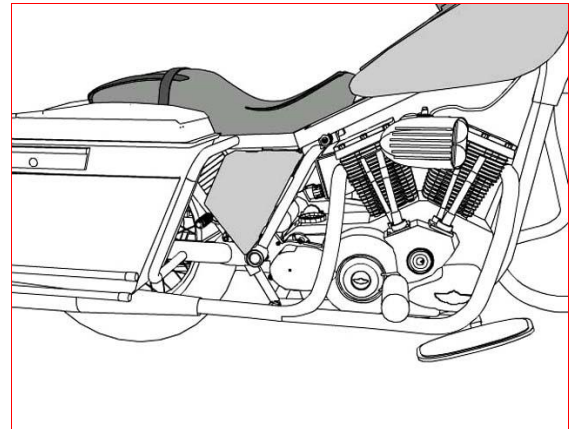

Figure 1

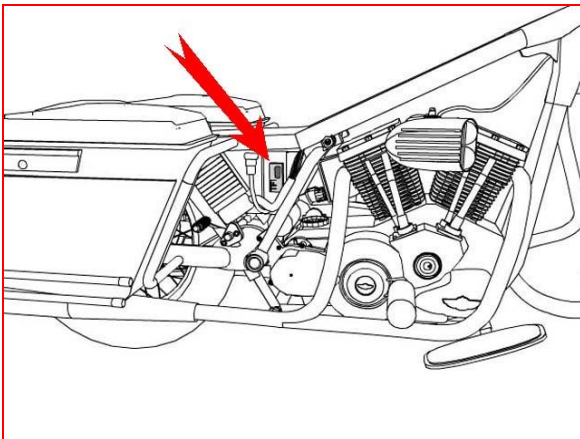

Figure 2

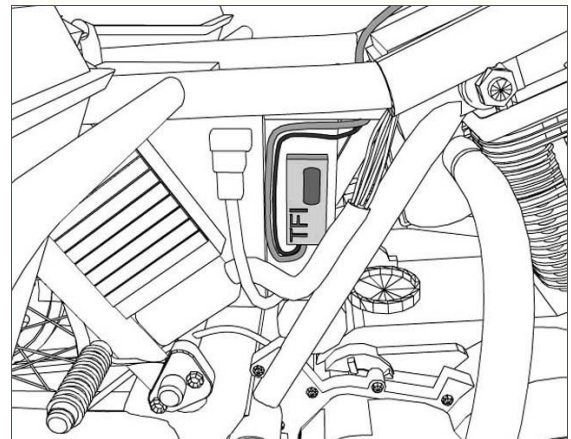

Figure 3



Figure 4

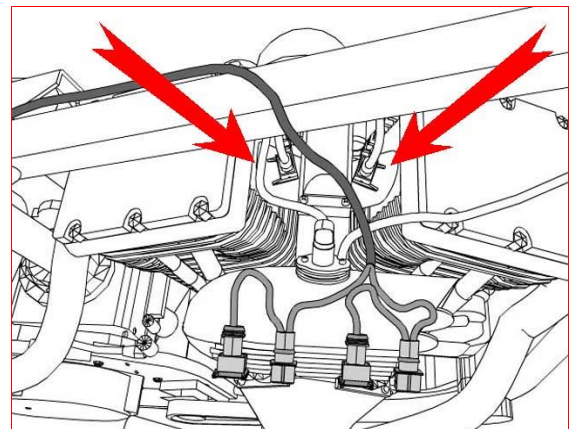

Figure 5

Electronic Jet Kit™ Instructions

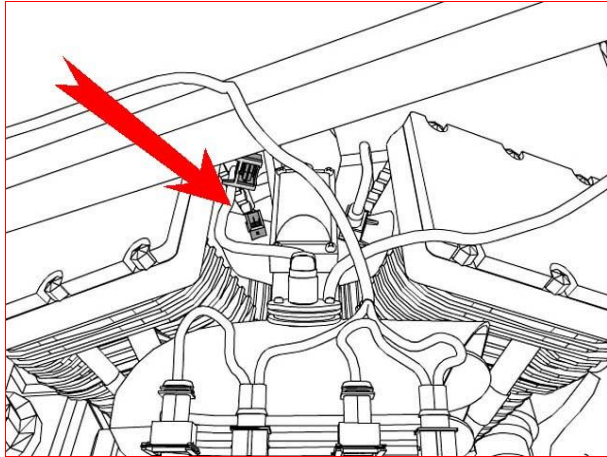

Figure 6

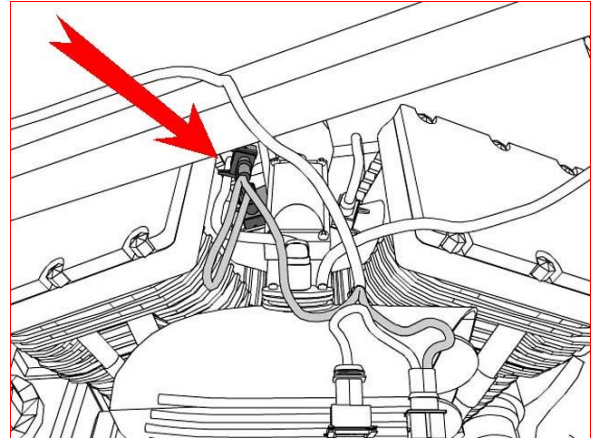

Figure 7

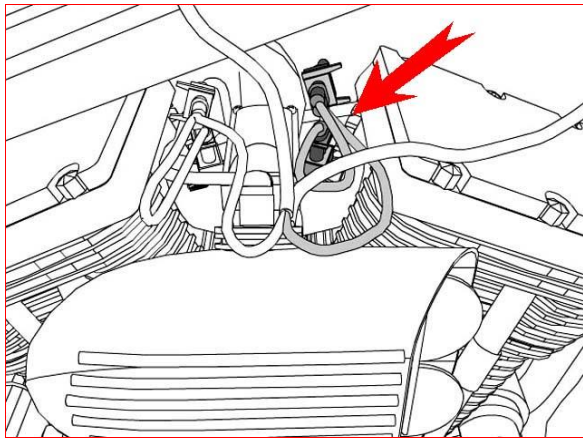

Figure 8

Electronic Jet Kit™ Instructions

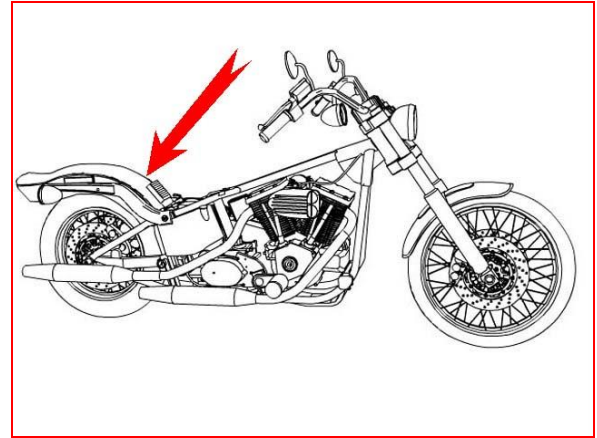
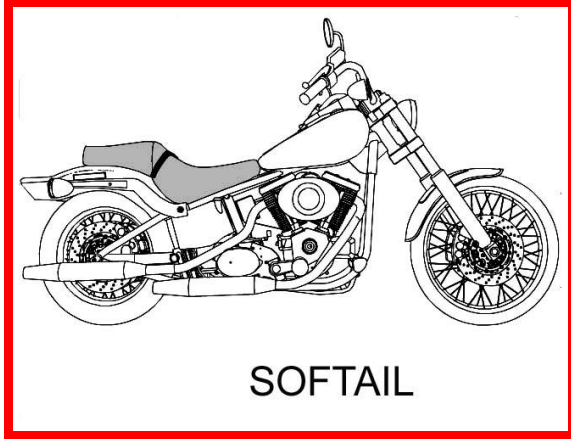

Figure 1

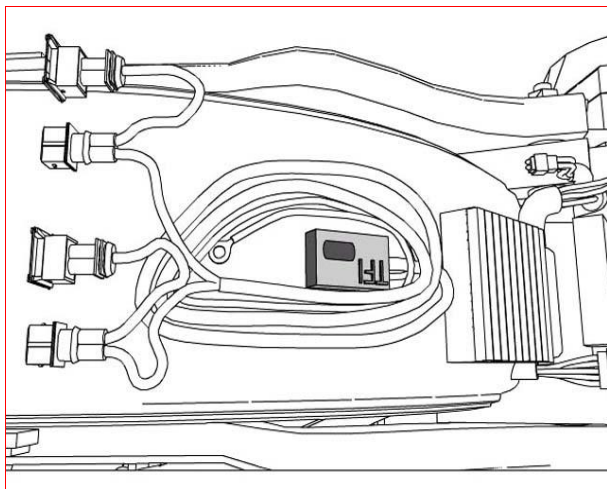

Figure 2

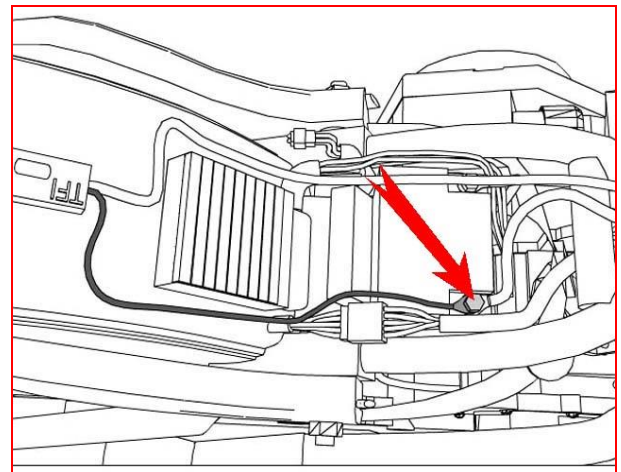

Figure 3

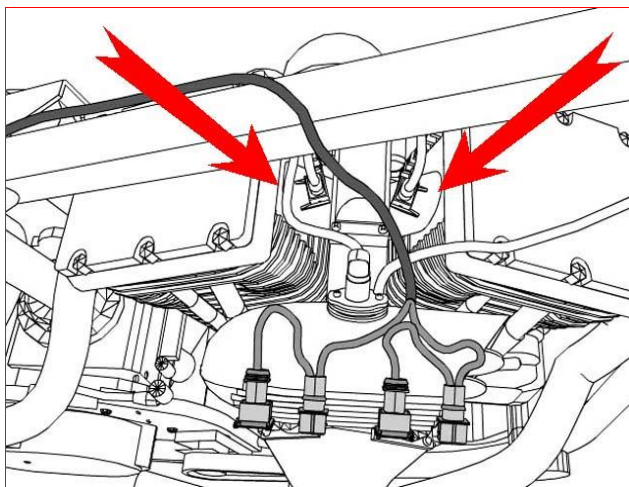

Figure 4

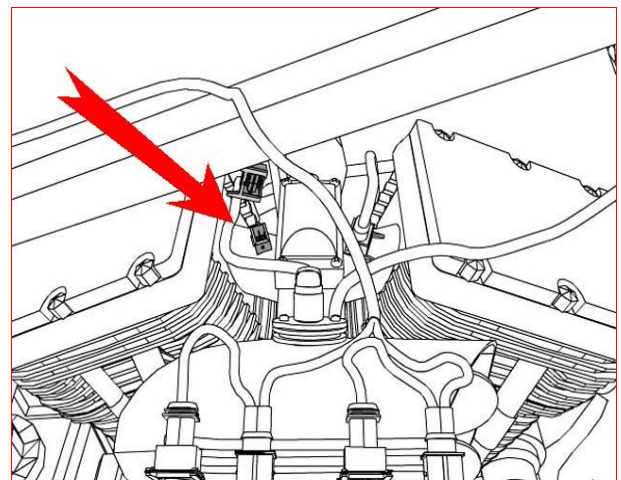

Figure 5

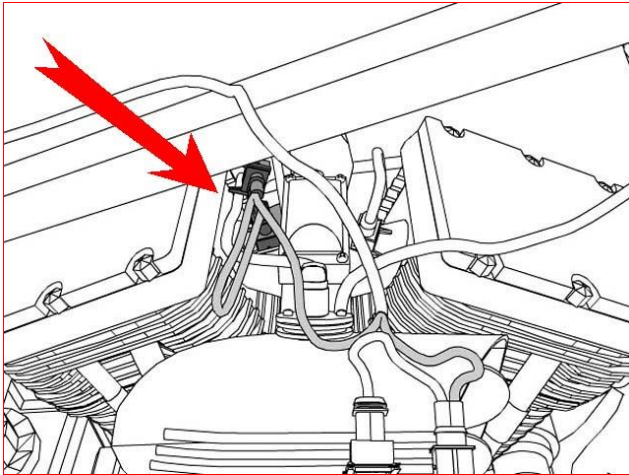

Figure 6

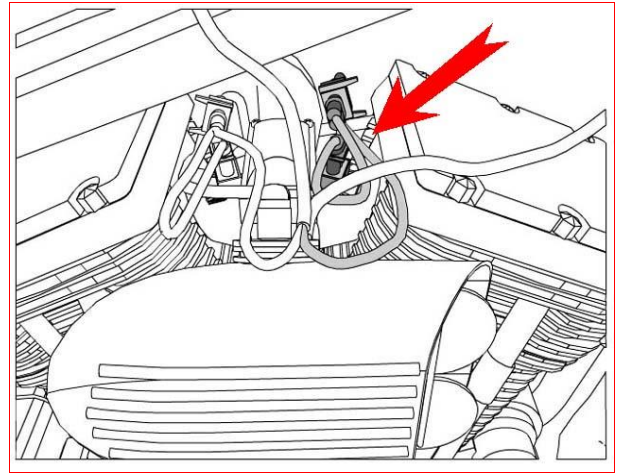

Figure 7



2-year Unlimited Mileage Warranty

Techlusion warrants that this product carries a warranty for 2-years from date of purchase against original defects in materials and workmanship. Should this product fail to perform for either of the above reasons, Techlusion will repair or replace it with an equivalent product at no charge, except for postage, to the original retail purchaser.

*****IMPORTANT*****

To obtain the benefits of this warranty, the retail purchaser must first call 1-877-764-3337 to obtain a Return Authorization Number, then send the product with proof of purchase and postage prepaid to:

**Dobeck Performance
157 Progressive Dr.
Belgrade, MT 59714**

Electronic Jet Kit™ Instructions



Insert Harley 2

All Stock - No Downloads

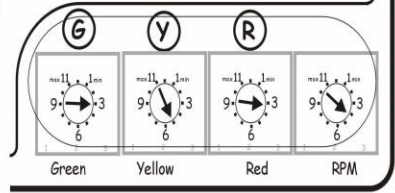

Stage 3 Motor - No Download 80+ Horsepower

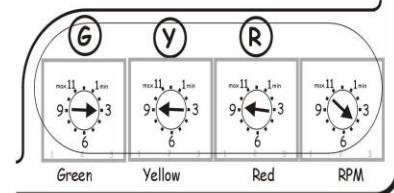

Aftermarket Air Cleaner, Exhaust - No Downloads

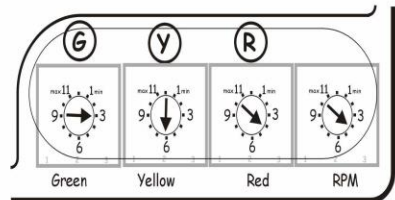

Stage 3 Motor - #2 Download 80+ Horsepower

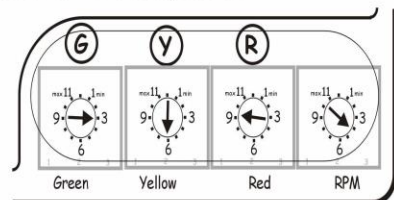

Aftermarket #1 Download - Air Cleaner, Exhaust

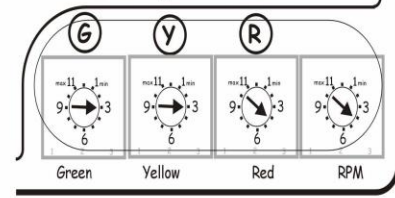

Stage 2 Motor - No download 95 cu.in., Cams, Exhaust

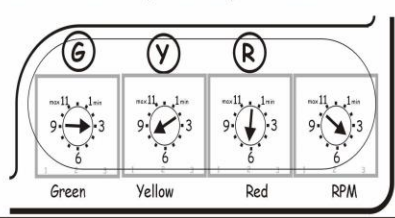

Stage 2 Motor - #2 Download 95 cu.in., Cams, Exhaust

